

PLAN

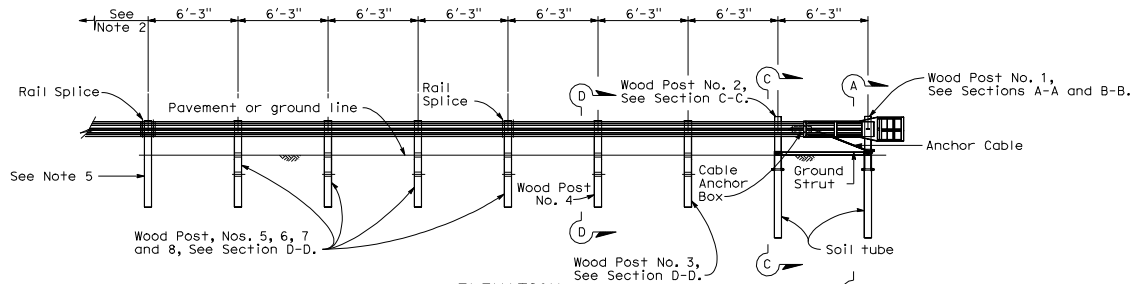

ELEVATION
TERMINAL SYSTEM (TYPE SKT)

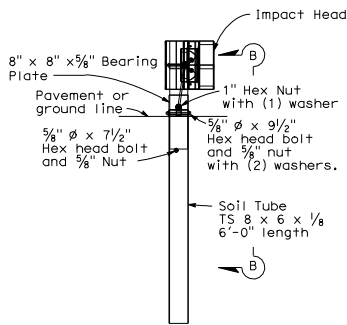

SECTION A-A
Post No. 1

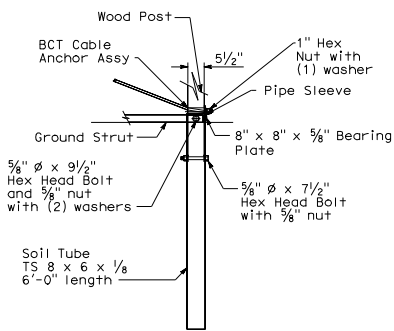

SECTION B-B
Partial view Post No. 1

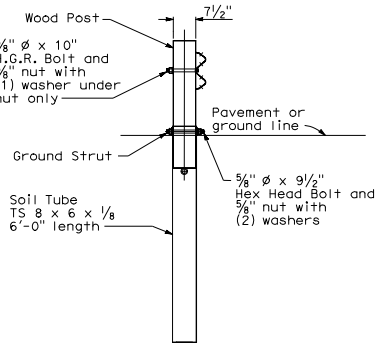

SECTION C-C
at Post No. 2

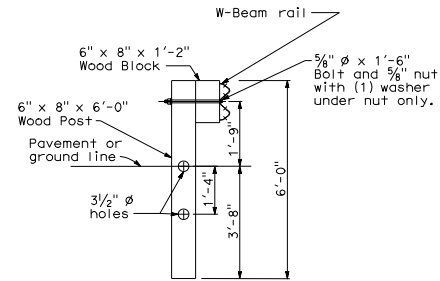

SECTION D-D
Post No. 3 through No. 8

| DIST | COUNTY | ROUTE | POST MILES TOTAL PROJECT | SHEET NO. | TOTAL SHEETS |
|------|--------|-------|--------------------------|-----------|--------------|
| | | | | | |

Randell D. Hiatt
REGISTERED CIVIL ENGINEER

May 1, 2006
PLANS APPROVAL DATE

Randell D. Hiatt
No. C50200
Exp. 6-30-07
REGISTERED PROFESSIONAL ENGINEER
CIVIL
STATE OF CALIFORNIA

The State of California or its officers or agents shall not be responsible for the accuracy or completeness of electronic copies of this plan sheet.

To get to the Caltrans web site, go to <http://www.dot.ca.gov>

NOTES:

- For additional details of Terminal System (Type SKT), refer to the manufacturer's installation instructions.
- Terminal System (Type SKT) must be constructed so that the full length of the terminal system guard railing is in straight alignment. Terminal System (Type SKT) can be flared at a maximum rate of 25:1 to prevent the impact head from encroaching on the shoulder. The flare is not required and may be decreased or eliminated for specific installations.
- Terminal System (Type SKT) not to be used where extrusion of the rail on the back side of the installation would be in the path of pedestrian traffic or where there is less than 25'-0" between the outlet side of the impacted Head and any adjacent vehicle traffic.
- For the length and type of metal beam guard railing or metal barrier railing the terminal system is attached to, see Project Plans. For typical use of this terminal system with guard railing, see the A77E, A77F and A77G Series of the Standard Plans.
- Attach rail element to this post and block. Payment for this post, block and hardware is included in payment for the type of railing or barrier the terminal system is attached to, not part of payment for Terminal System (Type SKT).

STATE OF CALIFORNIA
DEPARTMENT OF TRANSPORTATION
**METAL BEAM RAILING
TERMINAL SYSTEM
(TYPE SKT)**

NO SCALE

A77L2