

DIST	COUNTY	ROUTE	POST MILES TOTAL PROJECT	SHEET TOTAL SHEETS

REGISTERED CIVIL ENGINEER
Tillot Satter
No. C42892
Exp. 3-31-18
CIVIL
STATE OF CALIFORNIA

January 20, 2017
PLANS APPROVAL DATE

THE STATE OF CALIFORNIA OR ITS OFFICERS OR AGENTS SHALL NOT BE RESPONSIBLE FOR THE ACCURACY OR COMPLETENESS OF SCANNED COPIES OF THIS PLAN SHEET.

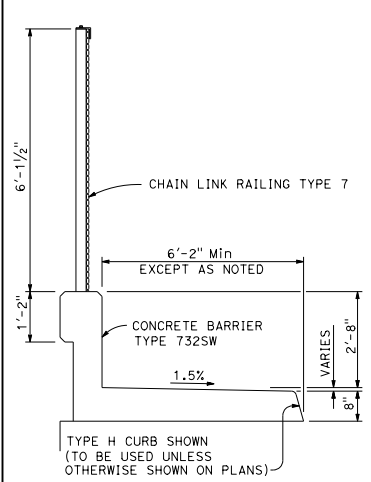

TYPICAL SECTION

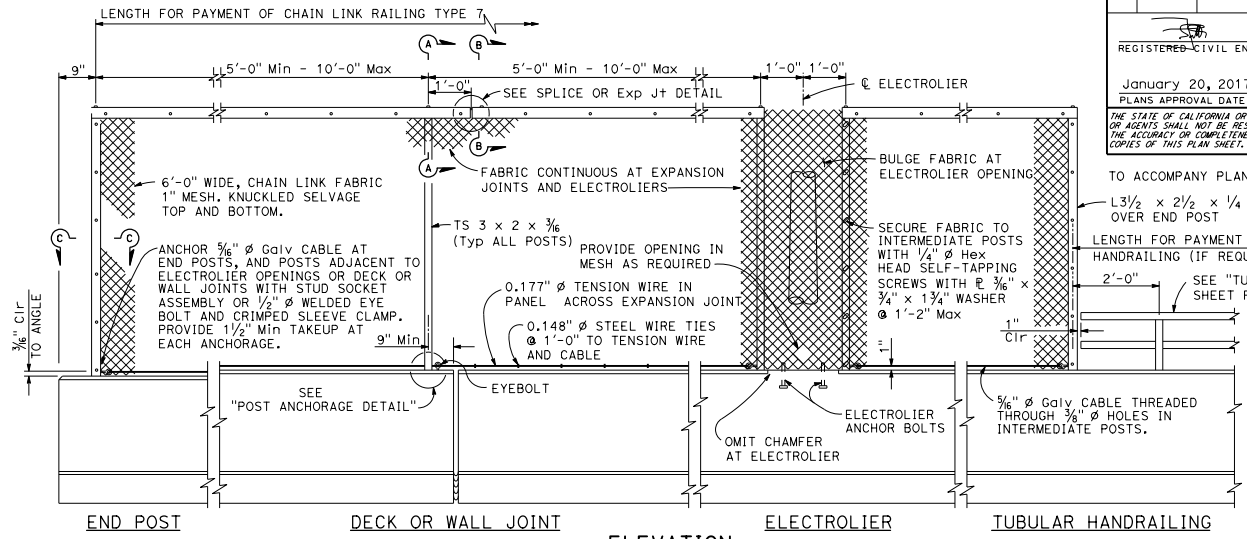

ELEVATION

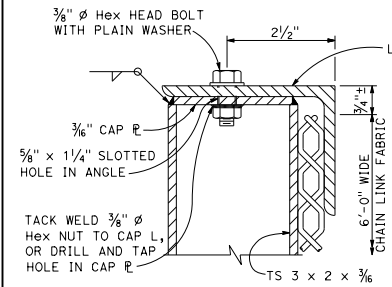

SECTION A-A

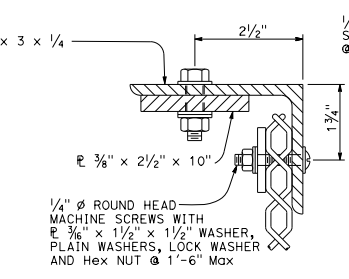

SECTION B-B

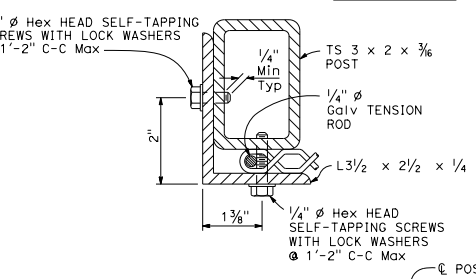

SECTION C-C

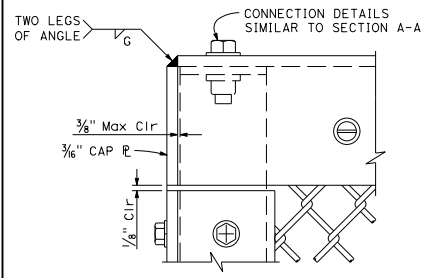

END POST ELEVATION

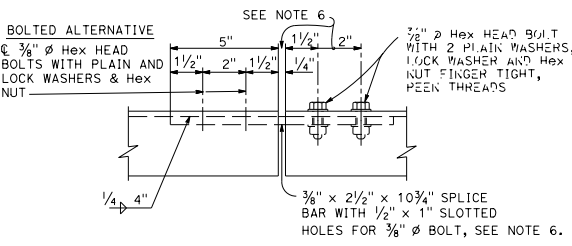

SPLICE OR EXPANSION JOINT DETAIL

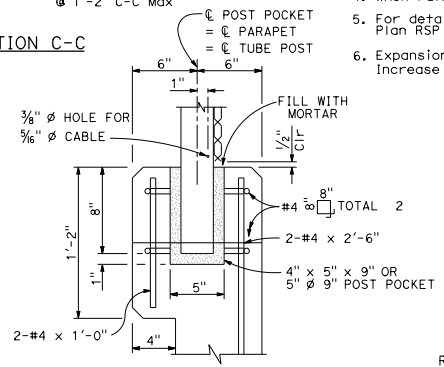

POST ANCHORAGE DETAIL

NOTES:

1. Posts shall be vertical.
2. Railing shall conform to horizontal and vertical alignment. When railing is placed on a curved horizontal alignment with radius of 148'-0" or less, thread the 3/8" ϕ cable through 3/8" ϕ welded eye rods embedded 4" into the top of the concrete parapet and equally spaced to limit the midordinate distance between the 3/8" ϕ cable and the curve to 1" maximum. Horizontal angle shall be bent to conform to horizontal alignment if radius is 148'-0" or less and may be on 10'-0" chords if radius is over 148'-0".
3. Horizontal angle shall be continuous over not less than two intermediate posts, except that a shorter length is permitted at expansion joints, electroliers and other rail discontinuities.
4. When rail is on slope, place fabric parallel to slope.
5. For details and reinforcement not shown see Revised Standard Plan RSP B11-54.
6. Expansion joint same dimension as expansion joint in deck or wall. Increase slotted hole length and splice bar length correspondingly.

STATE OF CALIFORNIA
DEPARTMENT OF TRANSPORTATION
**CHAIN LINK RAILING
TYPE 7**

NO SCALE

RSP B11-52 DATED JANUARY 20, 2017 SUPERSEDES RSP B11-52
DATED OCTOBER 30, 2015 - PAGE 313 OF THE STANDARD PLANS BOOK DATED 2015.
REVISED STANDARD PLAN RSP B11-52

2015 REVISED STANDARD PLAN RSP B11-52